

H-Tech LED High Bay Light



- Philips Lumileds LED source.High luminous efficiency and long life.
- High efficiency LED driver ,the wide input voltage is AC100-277V
- Light efficiency>90LM/W, CRI >75
- Heat pipe with FIN cooling design,better cooling,.LED Tj<85°C
- The products got the RoHS , UL&CUL ,FCC,DLC certification
- Excellent lampshade design,greatly improve the light utilization and evenness

- Dimmable Control gear, Energy-saving, convenient and user-friendly

Parameter

Type	CH-TJ-60W	Input Voltage	100-277V/50-60Hz
Light Source	PHILIPS Lumileds	Dimming	NO(Upon Request)
Power	60W	Power Factor	0.95
Beam Angle	120°	THD	<15%
Luminous Flux	More than 5400LM	Connection	3 Polors
Lumen Efficacy	Up to 90LM/W	Warranty	5 Years
Color Temperature	5000K(+/-400K)	IP Rating	IP67
Operating Temp.	-30-45°C	Replace For	120W(HID)
CRI	Ra75	Certification	UL.DLC.FCC.ROHS
Driver	MeanWell	UL Number	E472052

H-Tech LED High Bay Light

Light Distribution Curve(45° /90° /120°)

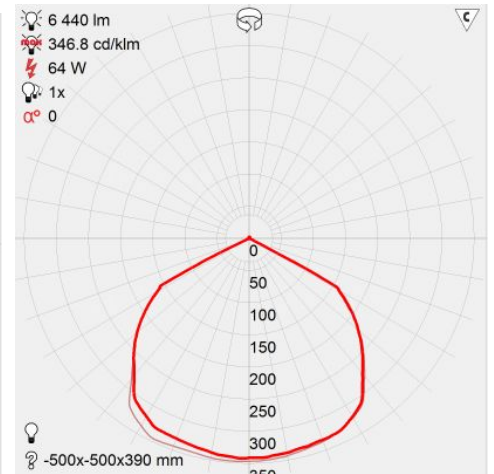
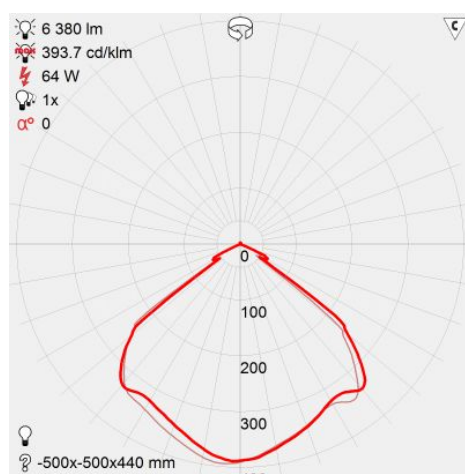
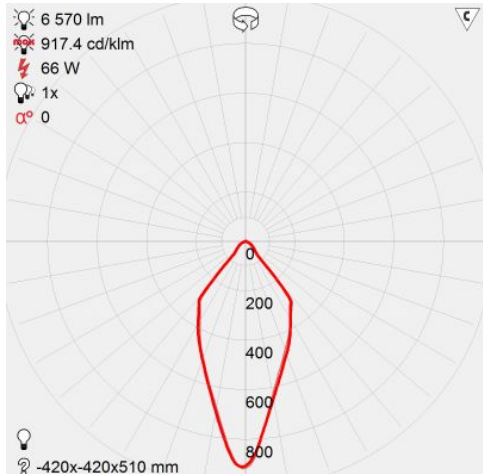

Application

LED High bay Light series can be widely used in indoor or half outdoor lighting, like Indoor parking, mechanical or electronic processing workshops, storage warehouses, steel mills, gas stations, toll booth, waiting rooms, the platforms of railway station etc



Temperature Compensation

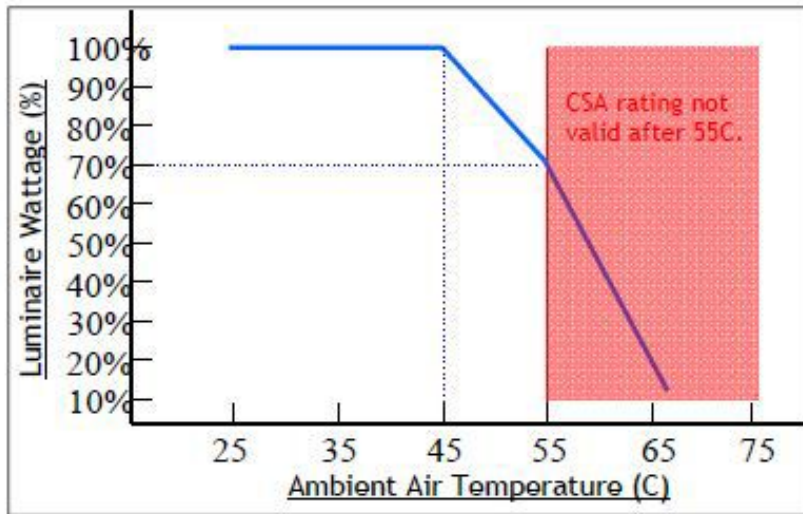

Control module activates at 45C. L70 output reached at 55C.

Continuous operation after 55C with increased compensation.

CSA certification valid to 55C only.

Chart accurate for Standard Output versions only.

Size

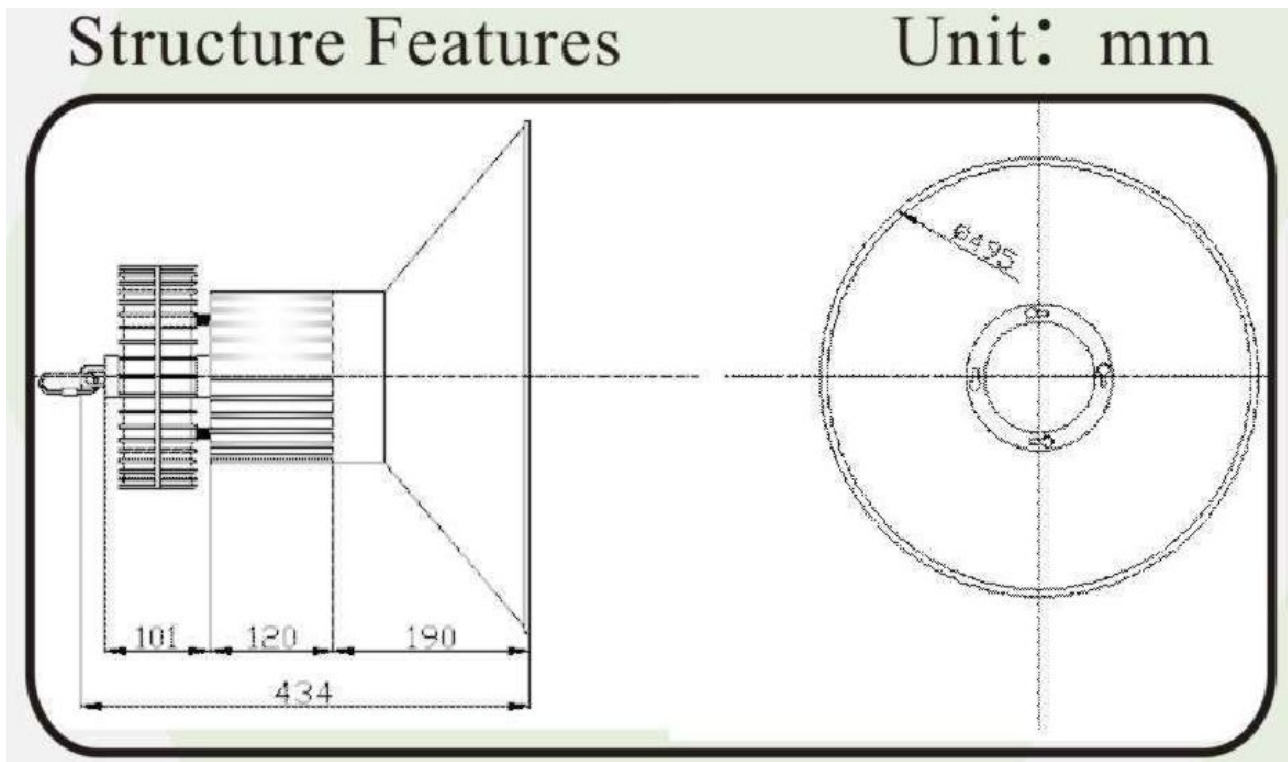

H-Tech LED High Bay Light

Installation

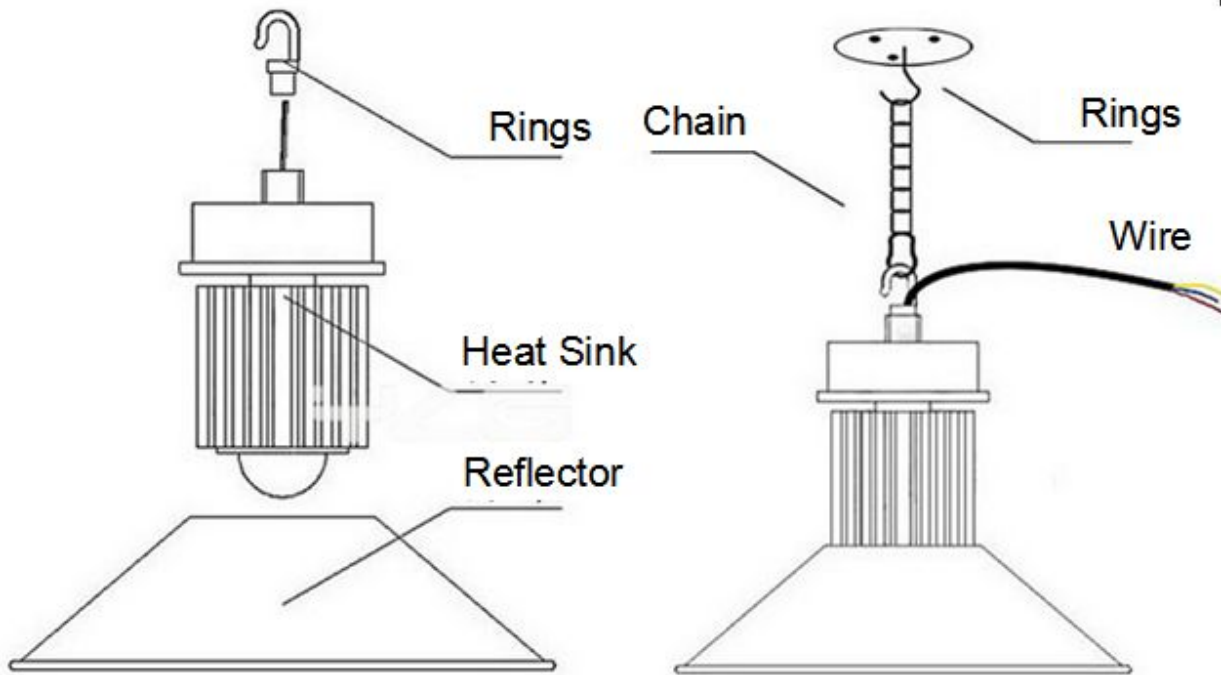

Packing details

Model	Meas	Qty	Net weight
CH-TJ-60W	493*493*434mm	1pcs/carton	5.5kg

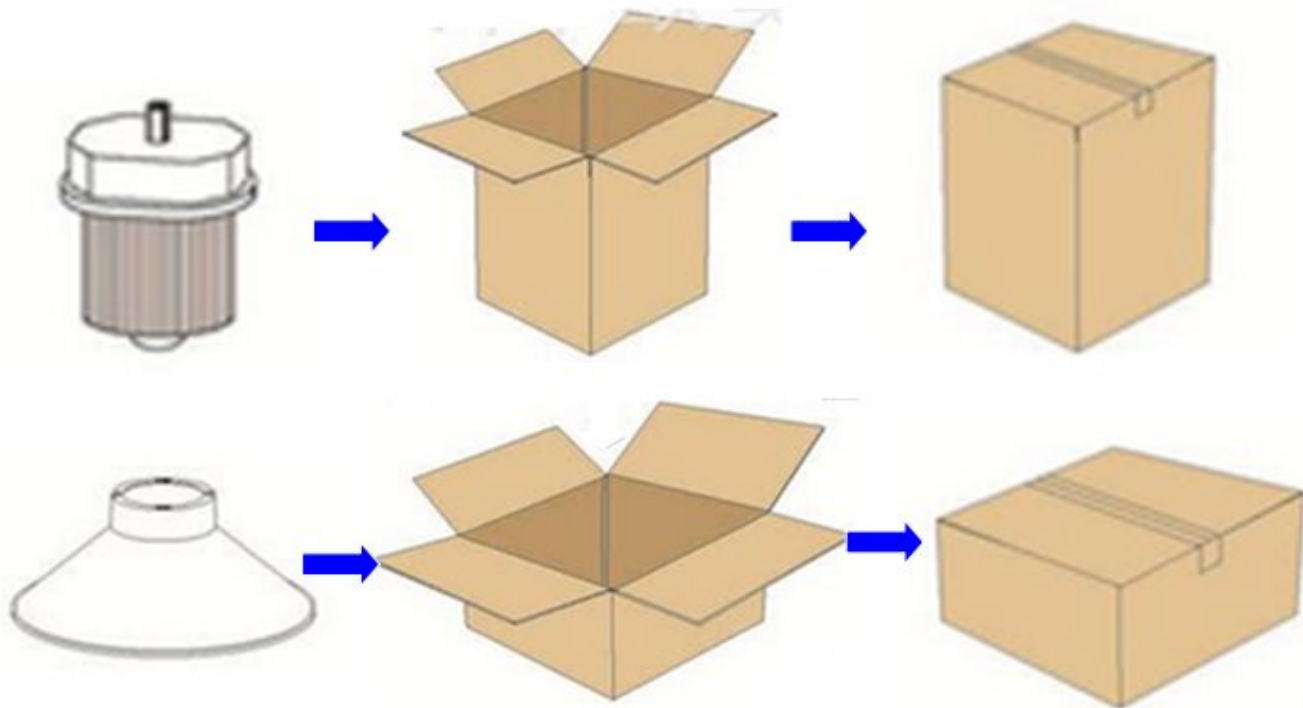

Lampshade Options

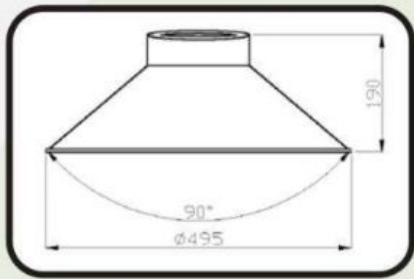

(AI Lampshade A)

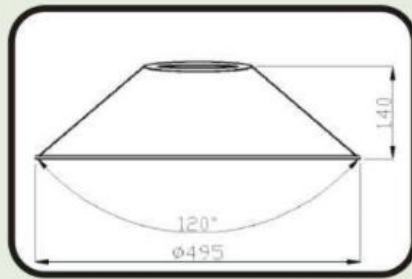

(AI Lampshade B)

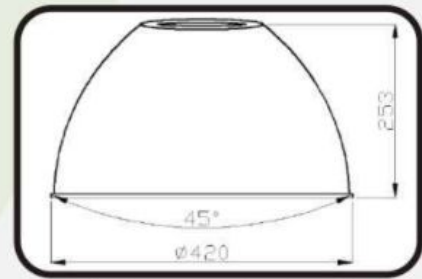

(AI Lampshade C)

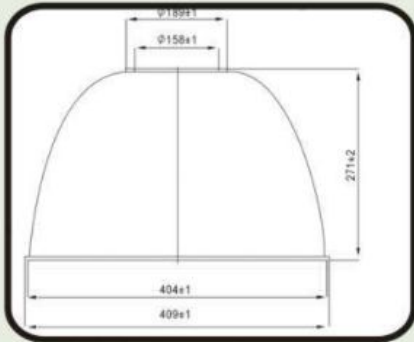

(PC Lampshade D)

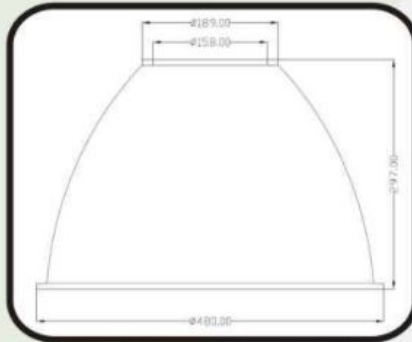

(PC Lampshade E)

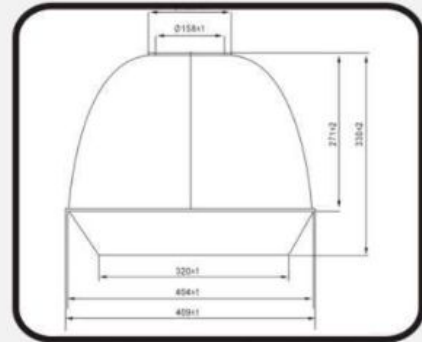

(PC Lampshade F)